

## technical data sheet AQQA®210-8 Article-No. 80100033 and AQQA® aeration unit Article-No. 80100002

**Complete pre-assembled unit for the filtration of water with submerged membrane plates. The unit comprises:**

- AQQA® membrane plates
- 3 pc. AQQA®80 frame
- 1 pc. AQQA® aeration unit with plate diffusers for medium size air bubbles

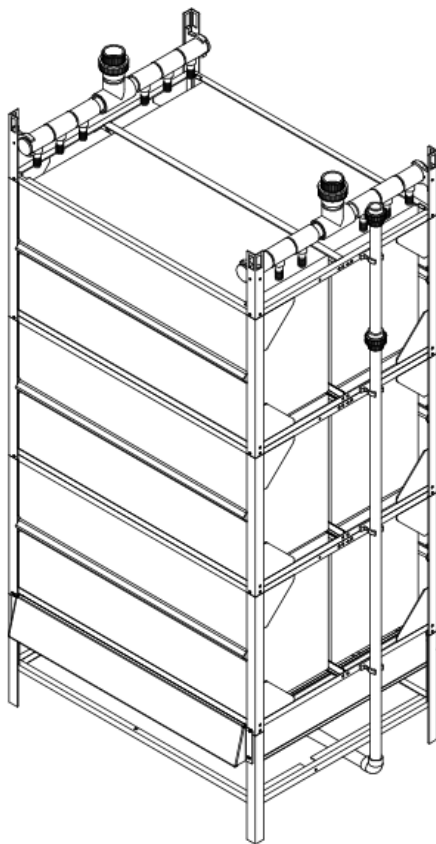

parameter	unit	value
dimension of filter housing (incl. flange for aeration)	l x w x h mm	1240 x 973 x 2520
<b>plate distance</b>	<b>mm</b>	<b>8</b>
Minimum water level	Mm	2300
air connection	d mm	40
filtrate connection 2 piece	d mm	63
number of AQQA® membrane plates		444
total membrane surface area	m <sup>2</sup>	210
typical design flow in MBR <sup>1</sup>	m <sup>3</sup> /h	6,3
max. flow in MBR <sup>1</sup>	m <sup>3</sup> /h	10,5
max. air flow	Nm <sup>3</sup> /h	90
design air flow	Nm <sup>3</sup> /h	60
filtration pressure	mbar	-30 ...-500
backflush pressure	mbar	350
pore size nominal	µm	0,04
frame material		1.4301
frame material (optional)		1.4571
membrane material		PES
max. operating temperature	°C	50
max. pH-range		1-12
weight dry	kg	450
weight wet	kg	900

<sup>1</sup> depending on wastewater characteristics

# AQQA®

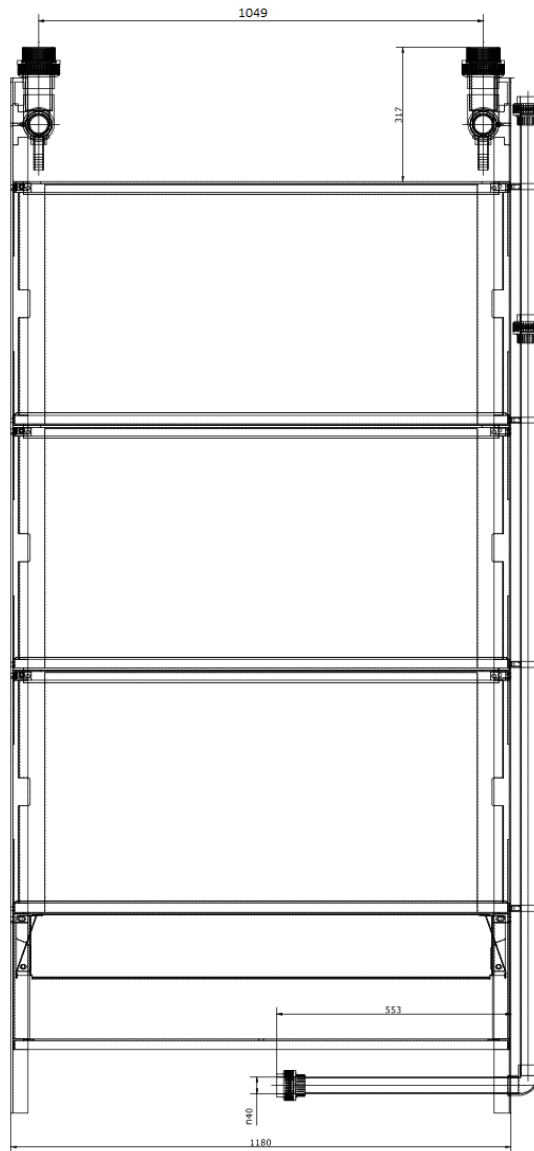
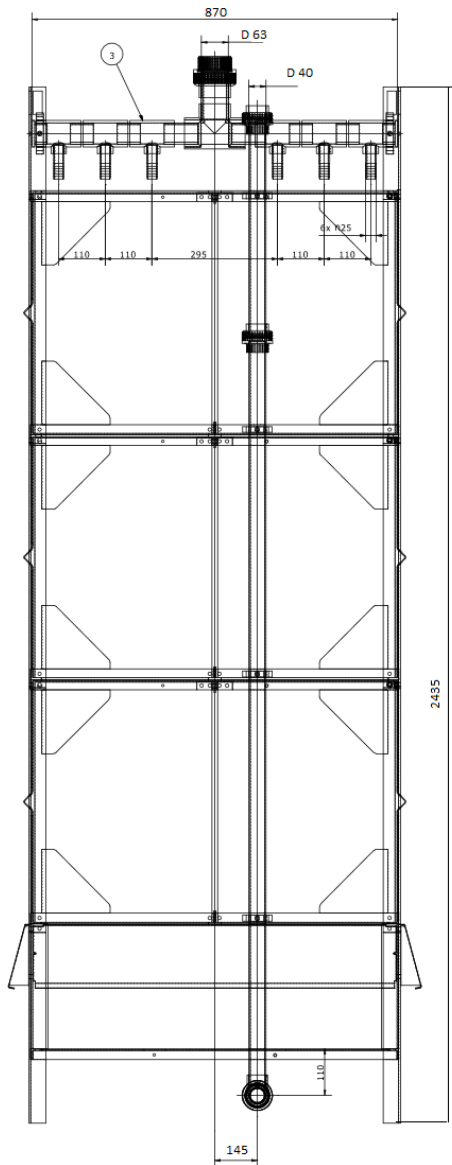

Revised: 07.11.2022  
Design and specifications are subject to  
change without notice.

Weise Water GmbH  
Eduard-Maurer-Str. 13  
16761 Hennigsdorf  
Germany

Tel +49 (0) 3302 2031455  
Fax +49 (0) 3302 2090096  
Email [info@weise-water.de](mailto:info@weise-water.de)  
Web [www.weise-water.de](http://www.weise-water.de)